

产品使用 说明手册

PRODUCT
INSTRUCTION
MANUAL



HP60I Fiber Optic Welding Head Manual

PREFACE

前言

Thank you very much for using our products! Before use, please read the equipment operation manual carefully to ensure the correct use of the company's equipment. Please keep the manual properly for reference at any time. Due to different configurations, some models do not have some functions listed in this book. Please take the actual products as the standard. Due to the continuous upgrading and improvement of the products, some contents of this book may deviate from the actual products. Please take the actual products as the standard.

This manual provides the user with relevant instructions and precautions for installation, parameter setting and processing operation. In order to ensure the correct installation and operation of the system, please read this manual carefully before installation, and keep it properly or hand it to the user of the software.

For the safety of operators and mechanical equipment, please be sure to install and operate the equipment by professional process engineers. If you have any questions, please contact us in time, and our professionals will be happy to serve you

©Copyright notice

Wuhan Xinghong Photoelectric Technology Co., Ltd. reserves all rights

The copyright of the manual and other information provided are owned by Wuhan Xinghong Photoelectric Technology Co., Ltd.

The information in this manual can only be used for installation, training and service according to the original intention.

It is forbidden to transmit all or part of the information in written form, electronic processing or other ways without the permission of Wuhan Xingde optoelectronics Co., Ltd.

property right © Or trademark ™ The sign shall not be removed.



Reminder

Please be sure to read this product manual carefully

Then install, debug and use the product

When operating the laser equipment, you must wear safety glasses. Safety glasses shall be reasonably selected according to the laser wavelength emitted by the laser equipment. If the laser output of the device is beyond the normal wavelength range, it can be tuned for the laser protection. Laser safety glasses shall be selected according to the standard that they can shield the laser within the whole wavelength range emitted by the laser equipment.



Safety precautions



Before operating the equipment, users must carefully read this manual and relevant operation manuals, strictly abide by the operating procedures, non professionals are not allowed to start the machine, and all connected equipment must be connected to the earth protection line.



This equipment uses four kinds of lasers (strong laser radiation), which may cause the following accidents: introducing surrounding inflammables;

In the process of laser processing, other radiation and toxic and harmful gases may be produced due to different processing objects;

The direct irradiation of laser radiation will cause human injury. Therefore, the place where the equipment is used must be equipped with fire-fighting equipment. It is strictly prohibited to stack inflammable and explosive articles on the workbench and around the equipment. At the same time, it is necessary to keep good ventilation. Non professional operators are not allowed to approach the equipment.



The processing objects and emissions shall meet the requirements of local laws and regulations.

There may be risks in laser processing. Users should carefully consider whether the processed object is suitable for laser operation. There is high voltage or other potential hazards inside the laser equipment. It is strictly prohibited to disassemble it by non manufacturer professionals.

The machine and other associated equipment must be safely grounded before startup. It is forbidden to open any end cover when the equipment is working. During the operation of the equipment, the operator must observe the working conditions of the equipment at any time. In case of abnormal conditions, all power supplies shall be cut off immediately and corresponding measures shall be taken actively. When the equipment is turned on, special personnel must be on duty. It is strictly prohibited to leave without authorization. All power must be cut off before personnel leave.



There may be risks in laser processing. Users should carefully consider whether the processed object is suitable for laser operation. There is high voltage or other potential hazards inside the laser equipment. It is strictly prohibited to disassemble it by non manufacturer professionals.

The machine and other associated equipment must be safely grounded before startup. It is forbidden to open any end cover when the equipment is working. During the operation of the equipment, the operator must observe the working conditions of the equipment at any time. In case of abnormal conditions, all power supplies shall be cut off immediately and corresponding measures shall be taken actively. When the equipment is turned on, special personnel must be on duty. It is strictly prohibited to leave without authorization. All power must be cut off before personnel leave.



Do not look directly at the laser! Please use goggles conforming to DIN EN 207 and bgvb2 standards!



Please do not touch any part of your body with the laser head during exercise!



Residual temperature after cutting may burn!



The laser head is a precision product. Please do not impact!



Catalogue

01 Product Overview

- 1.1 Product structure diagram-----01
- 1.1 Product accessories display diagram-----02

02 Technical parameter

- 2.1 Technical parameter-----03

03 Installation and Link

- 3.1 Preparation before installation-----03
- 3.2 QBH connection-----03
- 3.3 Mounting of the welding head-----04
- 3.4 Diagram of blue light installation, gimbal side blow installation-----05
- 3.5 Wind knife, coaxial switching-----05

04 Debugging

- 4.1 CCD adjustment-----06
- 4.2 CCD field-of-view centripetal adjustment-----06
- 4.3 CCD image coincidence adjustment with laser centre-----06

05 Replacement and Maintenance of Protective Lenses

- 5.1 Replacement and maintenance of protective lenses-----07

06 Use and Maintenance

- 6.1 Cautions-----09
- 6.2 Maintenance and care of QBH and fibre optic connectors-----09
- 6.3 Precautions for regular maintenance of welding heads-----09

01. Product Overview

Product Name: Fibre optic welding heads

产品型号: HP60 (I)

Product features:

Water-cooled collimator and focus mirror holders for long and stable operation and long life

Integrated CCD with vision software

Drawer type design of the collimating and focusing mirror makes maintenance easier for the customer.

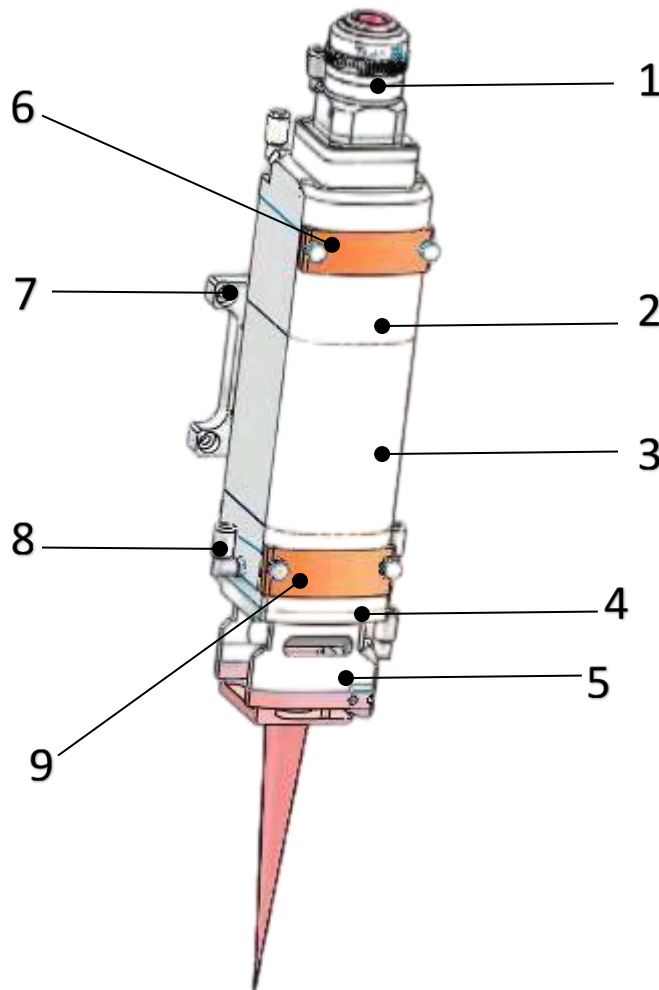

Hermetically sealed structure to protect the optics from contamination

1.1 Product structure diagram

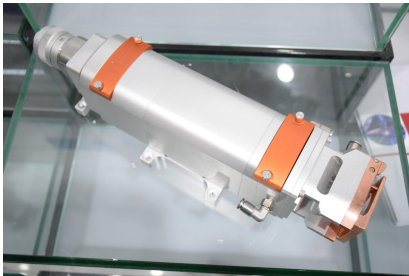

序号	名称
1	QBH connector
2	Collimated bodies
3	45° Combined Beam Mirror
4	Focused protective mirror construction
5	Air knife assembly
6	Collimating protective mirror drawer
7	Installation version (95X85-M6)
8	Cooling waterway inlet
9	Focusing protective mirror drawer

1.2 Product accessories display diagram

Serial number	Name	Specifications	Sample
1	Fibre optic welding heads	HP60 (I)	
2	Side-shaft blowing	CFDWXJ-00	
3	Protective sheets	D50*5-6KW (five pieces)	

02. Technical Parameter

2.1 Technical parameter

Product parameters	Technical parameter
Maximum power	6000W
Optical fiber interface	QBH/RD
Collimation	F100
Focusing	F150/F200/F250/F300/F400
Clear aperture	D46mm
Collimation protection	D50X5mm
Focus protection	D50X5mm
Shielding gas pressure	10、15、20、25par
Weight	5.93kg

03. Installation and Connection

3.1 Preparation before installation

► means of preparation

1. One set of metric hexagonal handle;
2. One bag of dust-free cleaning stick, one bottle of absolute ethanol (500ml) and one bag of dust-free gloves;
3. Clean dust-free working environment;

3.2 QBH connection

Step 1: rotate as shown in the figure below, and confirm that the red dot on the side of the rotating sleeve is in line with the white dot on the outer sleeve.

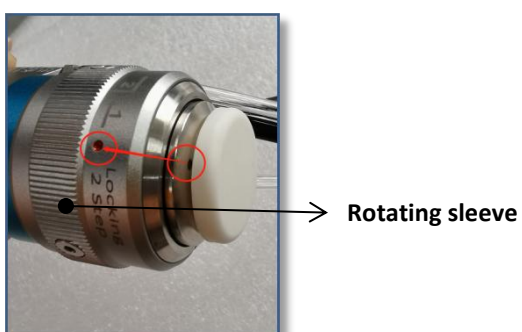

► Installer preparation

1. Read this manual carefully;
2. Wash hands with hand sanitizer first;
3. Wear dust-free gloves;
4. Wear a mask if necessary. (hint - dust removal is very important)

Step 2: clean the head of optical fiber rod and QBH connector with dust-free cleaning rod and absolute ethanol.



Optical fiber plug



QBH connector

Step 3: remove the dust cover of QBH, coaxial the cleaned optical fiber head with QBH, and ensure that the red dot on QBH is in the same line with the positioning slot of optical fiber head (long slot on optical fiber head), and then gently insert the optical fiber head into QBH until the two contact surfaces of optical fiber head and QBH fit.

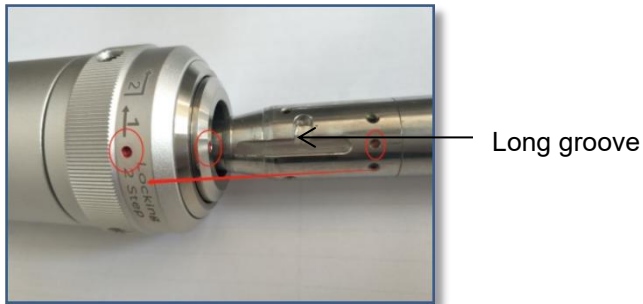

Step 4: after the optical fiber head is inserted into the QBH, lift the rotating sleeve by hand until the bottom surface of the rotating sleeve is basically flush with the top of the QBH, and then rotate the rotating sleeve clockwise until the clamping slot of the optical fiber head is locked. The rotation force should be moderate.

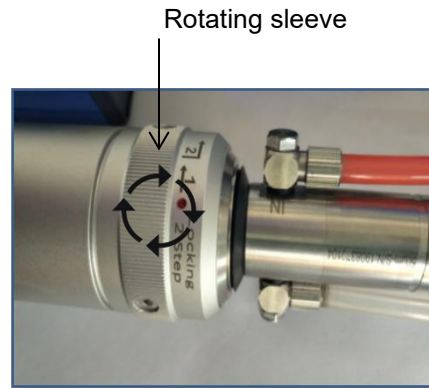

- Note: 1.Plug and unplug the optical fiber head gently;**
- 2. When plugging, make QBH and optical fiber connector go in and out of the same axis;**
- 3.Keep dust-free during operation**
- 4.Place the laser head horizontally when inserting the optical fiber; Ensure that the optical fiber is inserted horizontally**

3.3 Mounting of the welding head

Mounting adapter plate hole 95X85-M6,

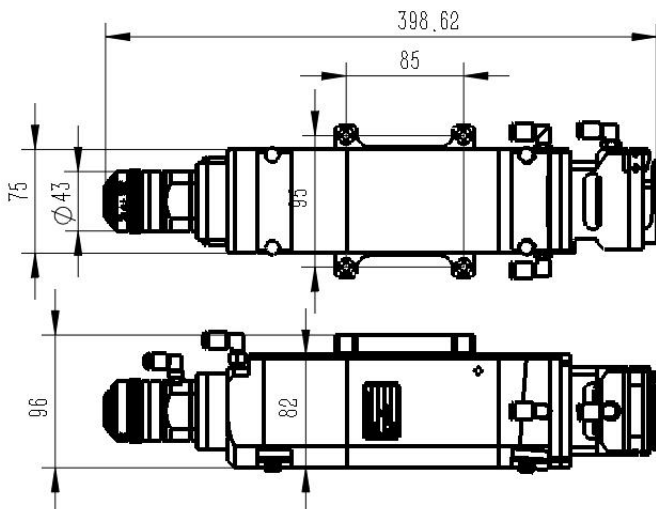

3.4 Diagram of blue light installation, gimbal side blow installation

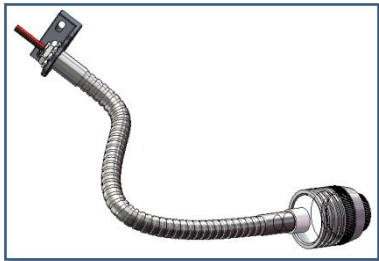

Blue light installation diagram

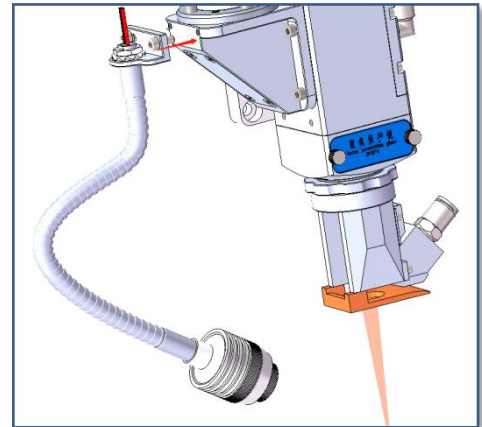
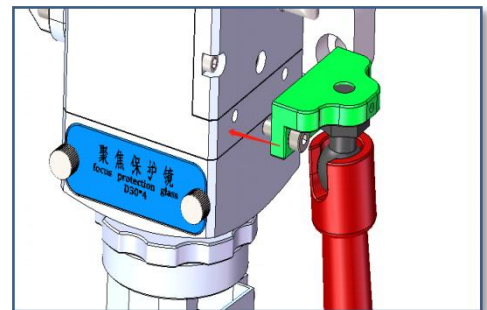
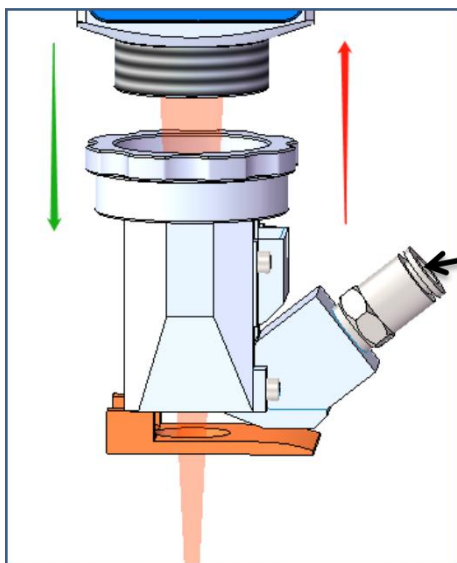

Diagram of universal joint side blow installation



3.5 Wind knife, coaxial switching



Airway connection s D6/D8

Airway connection s D6/D8

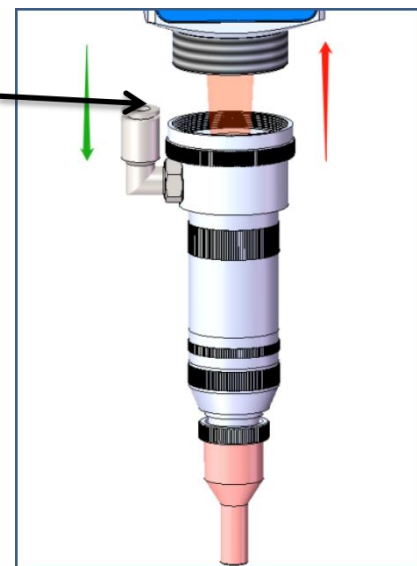

Wind knife: for the protection of the air curtain, usually used in long distance laser welding, clean compressed air can be used, air pressure: 10, 15, 20, 25 par, can be controlled according to the actual.

Coaxial: coaxial blowing gas for concentric protection gas, if you need a bright and bright weld pattern, available coaxial blowing gas, with protective gas, argon, nitrogen, CO2 and other inert gas b air pressure: 10, 15, 20, 25par, according to the actual demand control

04. Debugging

4.1 CCD sharpness adjustment

Clarity adjustment is achieved by adjusting the rotating outer knurled structure.

Note: Loosen the hand screw before adjustment to avoid damage to the internal structure

4.2 CCD field-of-view centripetal adjustment

Adjustment is made by loosening and tightening the 4 bolts on the lens flange and the 4 top wires polarisation adjustment for field of view alignment adjustment.

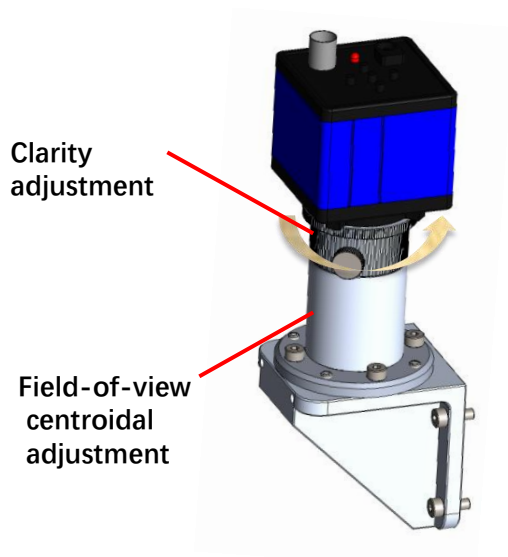

4.3 CCD image coincidence adjustment with laser centre

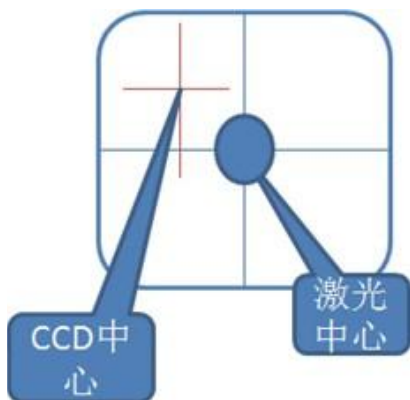

During operation, the centre of the CCD image (crossover point) must coincide with the laser centre.

05. Replacement and Maintenance of Protective Lenses

5.1 Replacement and maintenance of protective lenses

► Tools for cleaning and replacing protective lenses

1. powder-free rubber gloves or finger gloves, lint-free cleaning rags and cotton swabs.
2. Isoethanol (optical grade, water-free), acetone (optical grade, water-free).
3. compressed air (oil-free, water-free).
4. microscope, light source.

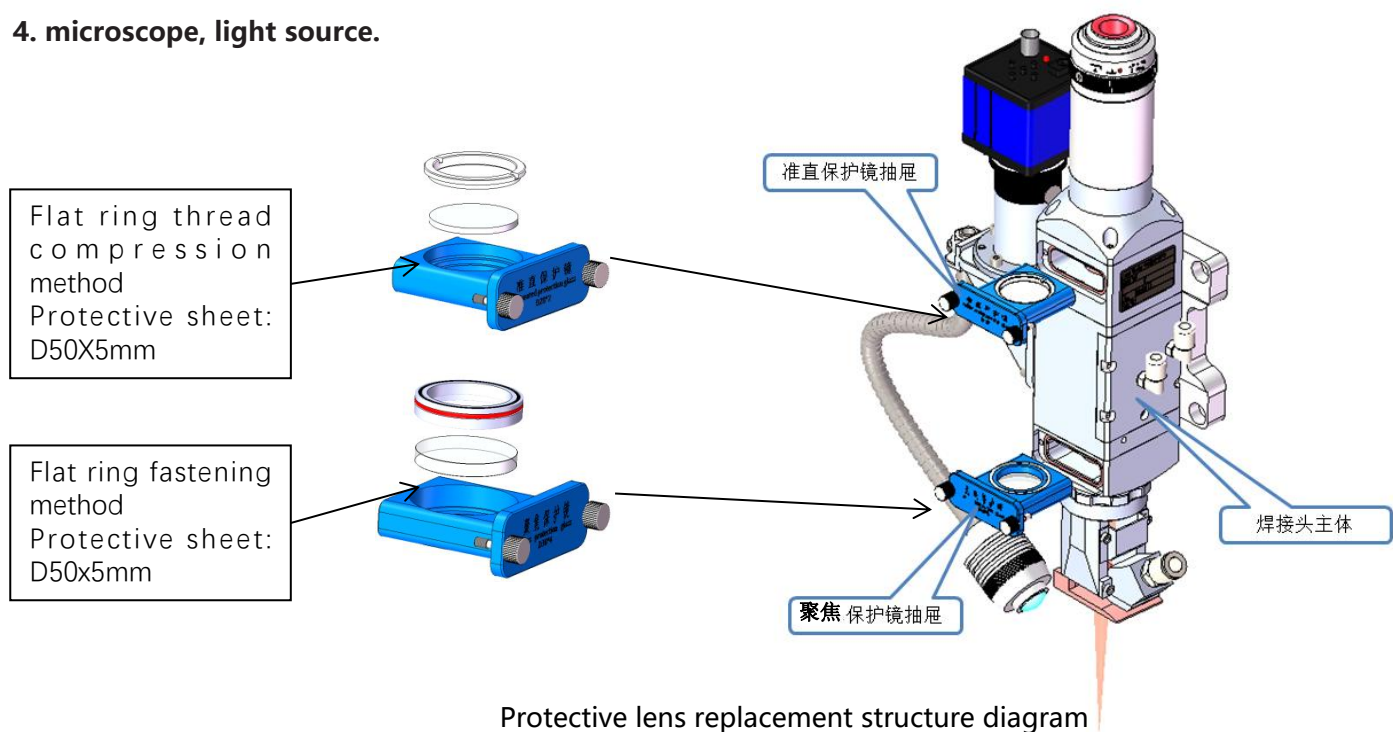

► Cleaning of protective lenses

1. Clean the lenses with a dust-free cleaning cuvette, using isopropyl alcohol solvent, and then use compressed air to suck up clean air and blow off any foreign objects such as attached columns;
2. Repeat several times until the lenses are clean.
3. The collimating lenses are a combination of two lenses, please note the direction;
4. If the protective lenses are no longer possible to clean or are damaged, they must be replaced with new lenses.

►Replacement and maintenance of protective lenses

1. Loosen the two locking nuts on the protective lens assembly by hand and pull out the protective lens drawer;
2. Note: Quickly seal the opening after the lens has been removed with a non-stick protective film!
3. Place the protective lens drawer (including the protective lens) in a clean environment for maintenance.
4. Remove the protective film from the laser head and insert the well maintained protective lens cover (including the lens) flat into the laser head and lock it in place.
- 5, Note: the direction of the protective lens cover, if the direction is reversed, it will not be inserted!
6. Hand tighten the two locking masters on the protective lens assembly with just the right amount of force.

►The process of replacing and removing protective lenses is as follows.

1. Use a special tool to unscrew the spring press ring until the spring press ring is completely unscrewed.
2. Place the entire collimator, unscrewed, upside down on a clean surface (keeping the collimator in the collimator during the process) and gently pull the collimator1 upwards, taking care not to drop the lens.
3. After removing the gasket placed on the lens, the lens can be replaced or serviced.
4. Once the lenses have been serviced or replaced, install them in the same order as they were removed, in reverse order to avoid damage to the lenses.
5. After screwing the spring-loaded ring to the end, back off 1/5 turn to ensure that the spring-loaded ring 3 has a clearance (0.1-0.15mm).

Note: Keep the original order between the parts and the lenses in the same orientation as before!

Caution.

- ★ Do not repeatedly wipe the protective lens with a lint-free cotton cloth or swab.
- ★ Do not touch the protective lenses with your fingers.
- ★ Do not blow directly on the surface of the protective lenses with your mouth, as this may introduce new dirt.
- ★ Do not touch the tip of the cleaning swab with your fingers.
- ★ Do not forget to clean the protective lens drawer when putting it back on.
- ★ When using compressed air, please do not blow directly on the dirt from the front, but use the side to avoid dirt diving into the surface.
- ★ **In particular**, it is important to wear powder-free gloves or finger gloves when cleaning the product. It is now expressly stated that if damage is caused by improper handling or use of incorrect cleaning procedures or chemical usage, damage due to such causes is not covered by the warranty.

06. Use and Maintenance

6.1 Cautions

1. Any parts fitted to the laser head must be carefully dusted!
2. If lenses have to be replaced, the work must be carried out in a clean environment!
3. Any assembly or component replacement must be carried out in a clean environment!
4. Before removing the old lens assembly, prepare a new one or, if no spare lens assembly is available, recommend purchasing one from our company!
5. When conditions are difficult to meet, seal the openings after removal of the lenses with a non-stick protective film!
6. Minimise the exposure of the laser head path to air to prevent the ingress of dust and dirt!
7. Any safety or protective equipment that has been removed must be reinstalled, checked and confirmed to be in good working order prior to operation or commissioning of the equipment.

6.2 Care and maintenance of QBH and fibre optic connectors

1. the connection between QBH and the fibre optic connector is covered with self-adhesive paper to avoid dust from entering and making maintenance more difficult.
2. Connect the cooling water pipe of the fiber optic connector well, no water leakage, if the QBH accidentally gets water, please stop using it immediately and return it to our company for treatment.

6.3 Precautions for regular maintenance of welding heads

1. regularly check the protective lenses for contamination and replace them if contaminated (daily check).
2. regularly check if the QBH connector is loose (every 3 days).
3. no water should enter the connection line, pay attention to the protection of the interface part.



兴弘光电

XINGHONG OPTOELECTRONIC



武汉兴弘光电技术有限公司

WUHANXINGHONG OPTOELECTRONIC TECHNOLOGY CO.,LTD

公司地址：武汉东湖新技术开发区流芳大道52号凤凰产业园（武汉·中国光谷文化创意产业园）B地块第B10栋2层（1）厂房号

咨询热线：027-81303883

网址：www.xhoptoelec.com