

产品使用 说明手册

PRODUCT
INSTRUCTION
MANUAL

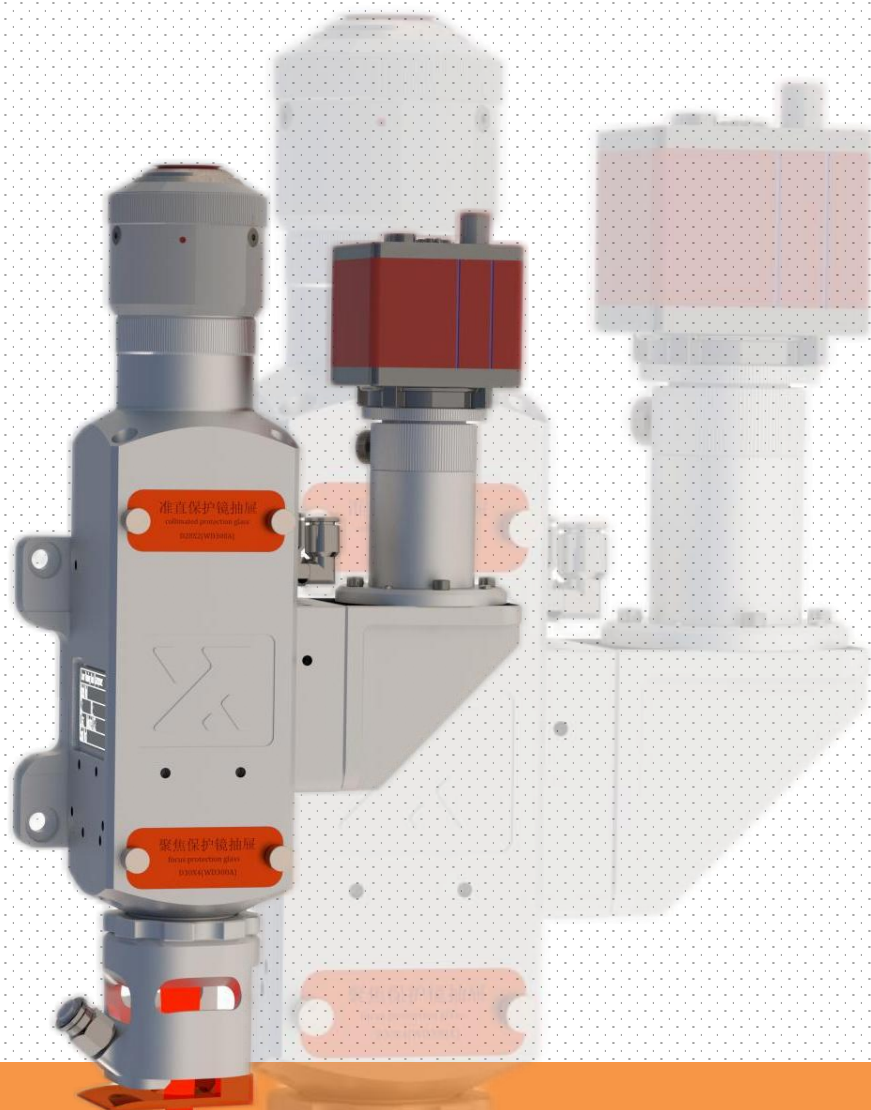

HP30

Specification of Optical Fiber Welding Joint

PREFACE

前言

Thank you very much for using our products! Before use, please read the equipment operation manual carefully to ensure the correct use of the company's equipment. Please keep the manual properly for reference at any time. Due to different configurations, some models do not have some functions listed in this book. Please take the actual products as the standard. Due to the continuous upgrading and improvement of the products, some contents of this book may deviate from the actual products. Please take the actual products as the standard.

This manual provides the user with relevant instructions and precautions for installation, parameter setting and processing operation. In order to ensure the correct installation and operation of the system, please read this manual carefully before installation, and keep it properly or hand it to the user of the software.

For the safety of operators and mechanical equipment, please be sure to install and operate the equipment by professional process engineers. If you have any questions, please contact us in time, and our professionals will be happy to serve you

©Copyright notice

Wuhan Xinghong Photoelectric Technology Co., Ltd. reserves all rights

The copyright of the manual and other information provided are owned by Wuhan Xinghong Photoelectric Technology Co., Ltd.

The information in this manual can only be used for installation, training and service according to the original intention.

It is forbidden to transmit all or part of the information in written form, electronic processing or other ways without the permission of Wuhan Xingde optoelectronics Co., Ltd.

property right © Or trademark ™ The sign shall not be removed.



Reminder

Please be sure to read this product manual carefully

Then install, debug and use the product

When operating the laser equipment, you must wear safety glasses. Safety glasses shall be reasonably selected according to the laser wavelength emitted by the laser equipment. If the laser output of the device is beyond the normal wavelength range, it can be tuned for the laser protection. Laser safety glasses shall be selected according to the standard that they can shield the laser within the whole wavelength range emitted by the laser equipment.



Safety precautions



Before operating the equipment, users must carefully read this manual and relevant operation manuals, strictly abide by the operating procedures, non professionals are not allowed to start the machine, and all connected equipment must be connected to the earth protection line.



This equipment uses four kinds of lasers (strong laser radiation), which may cause the following accidents: introducing surrounding inflammables;

In the process of laser processing, other radiation and toxic and harmful gases may be produced due to different processing objects;

The direct irradiation of laser radiation will cause human injury. Therefore, the place where the equipment is used must be equipped with fire-fighting equipment. It is strictly prohibited to stack inflammable and explosive articles on the workbench and around the equipment. At the same time, it is necessary to keep good ventilation. Non professional operators are not allowed to approach the equipment.



The processing objects and emissions shall meet the requirements of local laws and regulations.

There may be risks in laser processing. Users should carefully consider whether the processed object is suitable for laser operation. There is high voltage or other potential hazards inside the laser equipment. It is strictly prohibited to disassemble it by non manufacturer professionals.

The machine and other associated equipment must be safely grounded before startup. It is forbidden to open any end cover when the equipment is working. During the operation of the equipment, the operator must observe the working conditions of the equipment at any time. In case of abnormal conditions, all power supplies shall be cut off immediately and corresponding measures shall be taken actively. When the equipment is turned on, special personnel must be on duty. It is strictly prohibited to leave without authorization. All power must be cut off before personnel leave.



There may be risks in laser processing. Users should carefully consider whether the processed object is suitable for laser operation. There is high voltage or other potential hazards inside the laser equipment. It is strictly prohibited to disassemble it by non manufacturer professionals.

The machine and other associated equipment must be safely grounded before startup. It is forbidden to open any end cover when the equipment is working. During the operation of the equipment, the operator must observe the working conditions of the equipment at any time. In case of abnormal conditions, all power supplies shall be cut off immediately and corresponding measures shall be taken actively. When the equipment is turned on, special personnel must be on duty. It is strictly prohibited to leave without authorization. All power must be cut off before personnel leave.



Do not look directly at the laser! Please use goggles conforming to DIN EN 207 and bgvb2 standards!



Please do not touch any part of your body with the laser head during exercise!



Residual temperature after cutting may burn!



The laser head is a precision product. Please do not impact!



Catalogue

01 Product overview

- 1.1 Product structure diagram-----01
- 1.2 Product accessories display diagram-----02

02 Technical Parameter

- 2.1 technical parameter-----03

03 Installation and Link

- 3.1 Preparation before installation-----03
- 3.2 qbh connection-----03
- 3.3 Installation of welded joints-----03
- 3.4 Schematic diagram of blue light installation and universal joint side blowing installation-----04
- 3.5 Air knife, coaxial switching-----05

04 Debugging

- 4.1 CCD adjustment-----06

05 Replacement and Maintenance of Protective Lens

- 5.1 Replacement and maintenance of protective lens-----07

06 Use and Maintenance

- 6.1 matters needing attention-----09
- 6.2 Maintenance of QBH and optical fiber connector-----09
- 6.3 Precautions for regular maintenance of welded joints-----09

01. Product overview

Product Name: optical fiber welding joint

Product model: HP30

Product features:

The collimator and focusing lens seats are equipped with water cooling, which can work stably for a long time and prolong the service life

Integrated CCD with visual software

The collimating focusing protective mirror adopts drawer design, which makes customer maintenance more convenient and concise.

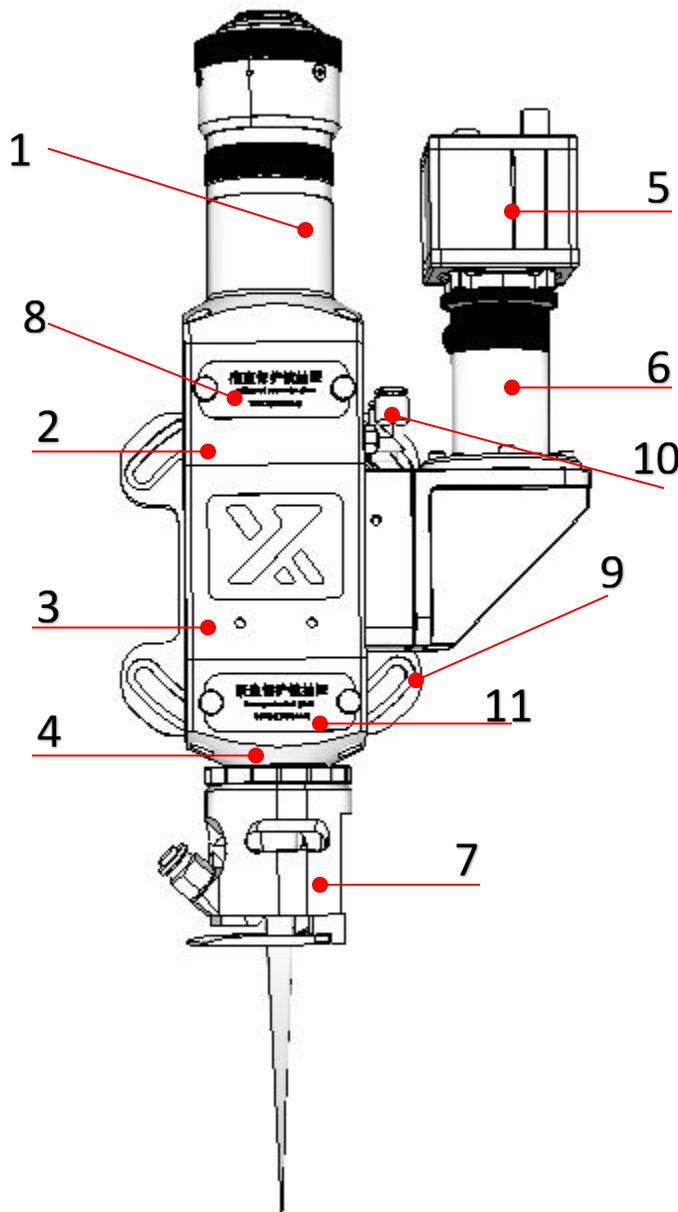

The sealed structure design can effectively protect the optical lens from pollution

1.1 Product structure diagram



Serial number	Name
1	QBH connector
2	Collimating body
3	45 ° beam combiner
4	Focusing protective mirror structure
5	CCD camera
6	CCD lens
7	Air knife assembly
8	Collimating protective mirror drawer
9	Installation version (85x75)
10	Cooling water inlet
11	Focus protection mirror drawer

1.2 Product accessories display diagram

Serial number	name	Specification	Sample
1	Fiber optic welding head	HP30 (Y型)	
2	8 inch monitor	XH-BNC-8	
3	12V power supply	AYD-1220	
4	BNC cable	XHPDL-5m	
5	Power Shunt Line	XHBNC-5m	
6	sideshaft blowing	CFDWXJ-00	
7	coaxial blow	XHTZCQ-F200	

8	air knife	XHFD30X-00	
9	protective sheet	D28*2	
10	blue light	LED-D16-500	
11	protective sheet	D30*4	

02. Technical Parameter

2.1 Technical parameter

Product parameters	Technical parameter
maximum power	3000W
Optical fiber interface	QBH
collimation	F100
focusing	F150/F200/F250/F300/F400
Luminous aperture	D26mm
Collimation protection	D28X2mm
Focus protection	D30X4mm
Shielding gas pressure	10、15、20、25par
weight	2.42KG

03. Installation and Connection

3.1 Preparation before installation

► means of preparation

1. One set of metric hexagonal handle;
2. One bag of dust-free cleaning stick, one bottle of absolute ethanol (500ml) and one bag of dust-free gloves;
3. Clean dust-free working environment;

► Installer preparation

1. Read this manual carefully;
2. Wash hands with hand sanitizer first;
3. Wear dust-free gloves;
4. Wear a mask if necessary. (hint - dust removal is very important)

3.2 QBH connection

Step 1: rotate as shown in the figure below, and confirm that the red dot on the side of the rotating sleeve is in line with the white dot on the outer sleeve.

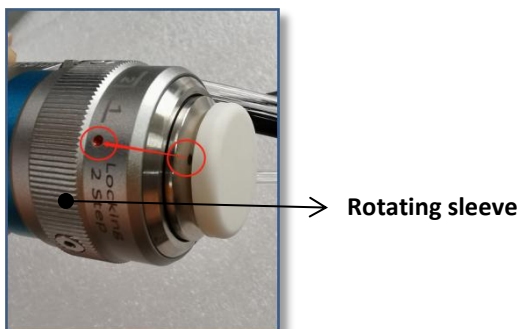

Optical fiber plug



QBH connector

Step 3: remove the dust cover of QBH, coaxial the cleaned optical fiber head with QBH, and ensure that the red dot on QBH is in the same line with the positioning slot of optical fiber head (long slot on optical fiber head), and then gently insert the optical fiber head into QBH until the two contact surfaces of optical fiber head and QBH fit.

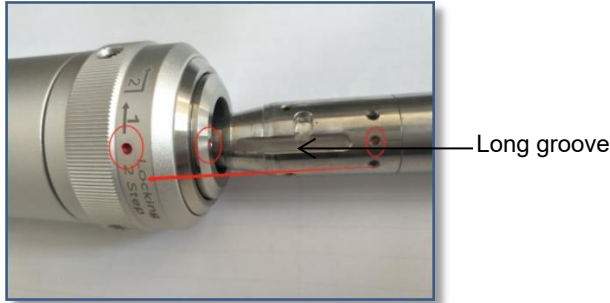

Step 4: after the optical fiber head is inserted into the QBH, lift the rotating sleeve by hand until the bottom surface of the rotating sleeve is basically flush with the top of the QBH, and then rotate the rotating sleeve clockwise until the clamping slot of the optical fiber head is locked. The rotation force should be moderate.

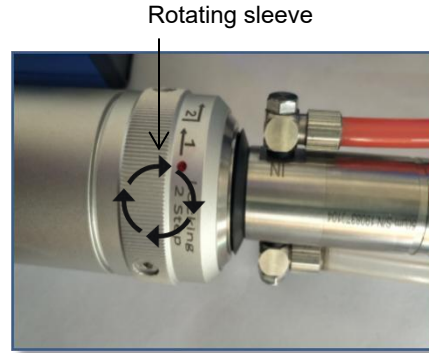

- Note:**
1. Plug and unplug the optical fiber head gently;
 2. When plugging, make QBH and optical fiber connector go in and out of the same axis;
 3. Keep dust-free during operation
 4. Place the laser head horizontally when inserting the optical fiber; Ensure that the optical fiber is inserted horizontally

3.3 Dimensional drawing of welding head and vacancy drawing of mounting board

Mounting adapter plate hole position 85x75-m6,

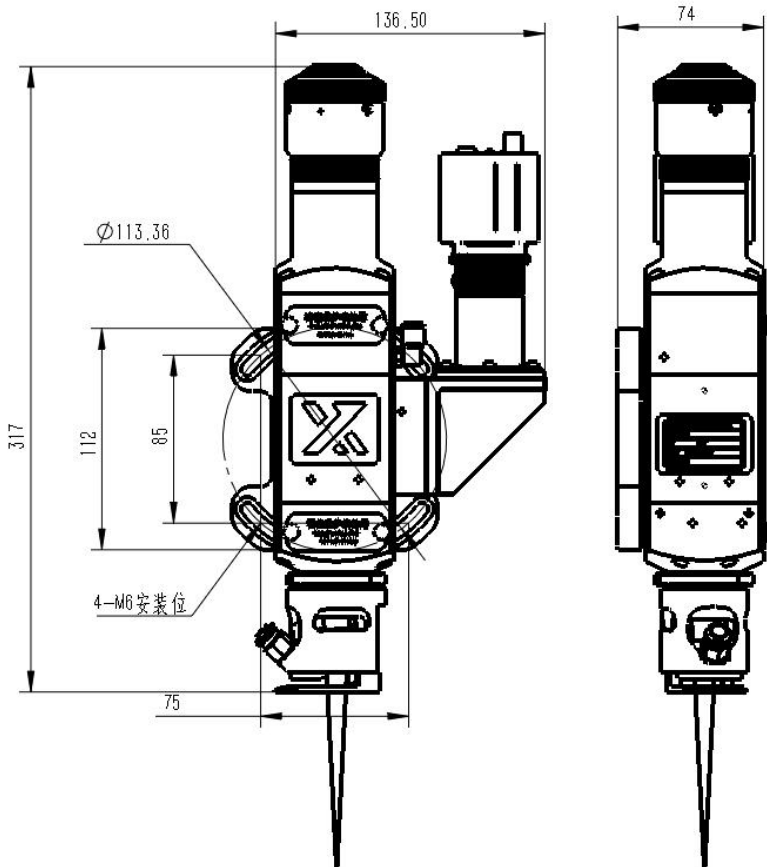

3.4 Schematic diagram of blue light installation and universal joint side blowing installation

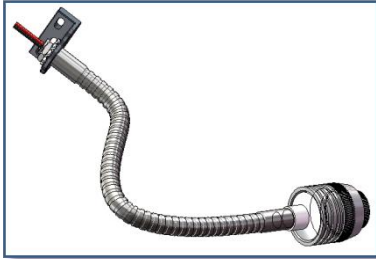

Blue light installation diagram

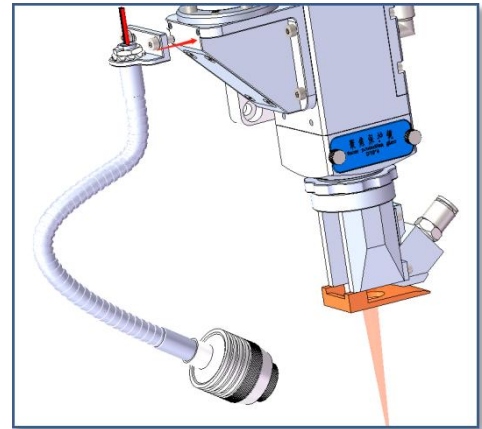

Installation diagram of universal joint side blowing

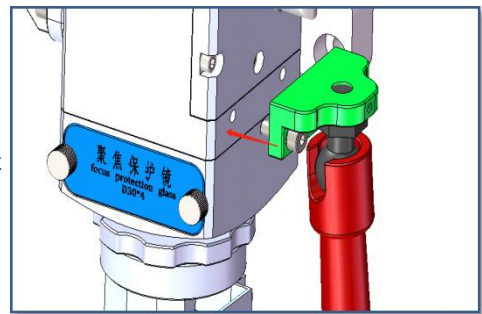

3.5 Air knife, coaxial switching

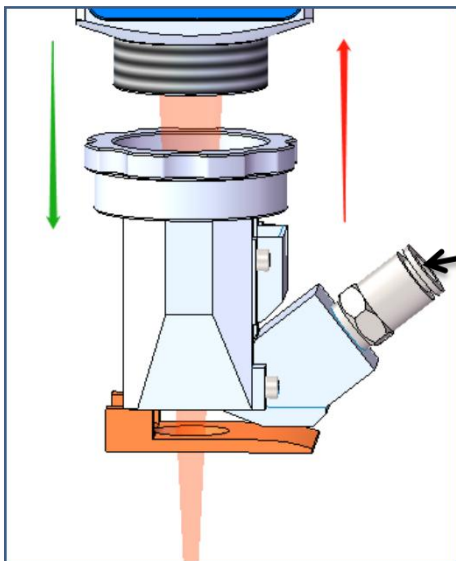

Airway interface D6/D8

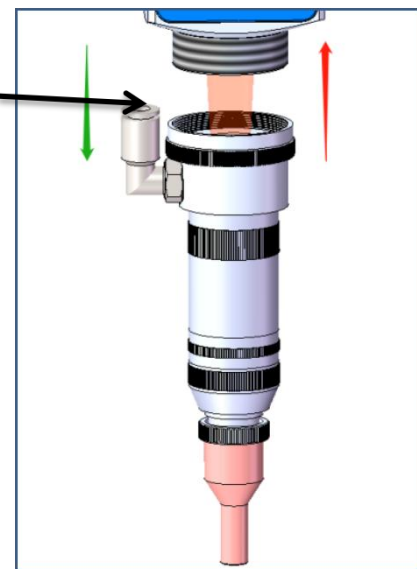

Airway interface D6/D8

Air knife: in order to protect the air curtain, it is usually used in long-distance laser welding. Clean compressed air can be used. The air pressure is 10, 15, 20 and 25par, which can be controlled according to the actual situation.

Coaxial: coaxial blowing is concentric shielding gas. If bright and bright weld lines are required, coaxial blowing can be used. Shielding gas, argon, nitrogen, CO2 and other inert gases B pressure: 10, 15, 20 and 25par, which can be controlled according to the actual demand

04. Debugging

4.1 CCD definition adjustment

By adjusting the rotating cylindrical knurling structure, the clarity can be adjusted.

Note: loosen the hand screwed bolts before adjustment to avoid damaging the internal structure

4.2 Centering adjustment of CCD field of view

Adjust the polarization by tightening the four bolts and four jackscrews on the lens flange to realize the field of view centering adjustment.

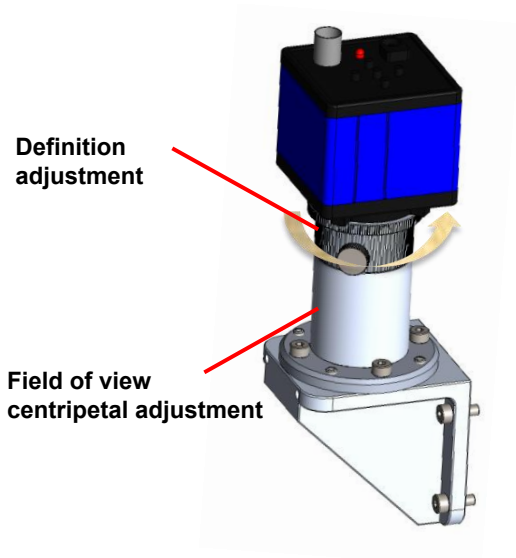

4.3 Adjustment of coincidence between CCD image and laser center

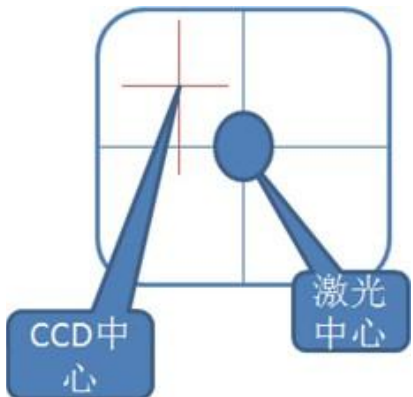

In the process of working, the CCD image center (cross point) must coincide with the laser center.

05. Replacement and maintenance of protective lens

5.1 Replacement and maintenance of protective lens

► Tools for cleaning and replacing protective lenses

- 1、 Powder free rubber gloves or finger covers, lint free cleaning rags and cotton swabs;
- 2、 Isoethanol (optical grade, anhydrous), acetone (optical grade, anhydrous);
- 3、 Compressed air (no oil, no water);
- 4、 Microscope, light source;

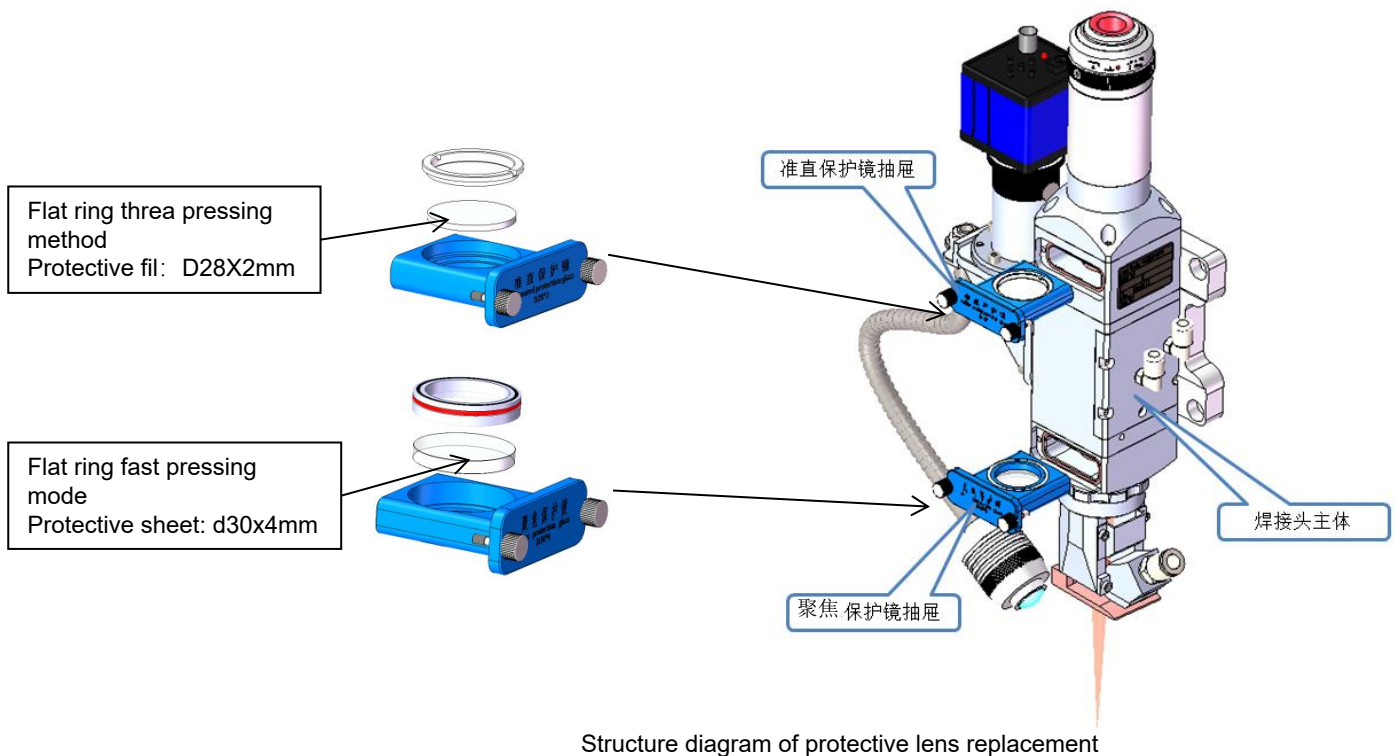

► Cleaning protective lenses

- 1、 Take isopropyl alcohol solvent with a dust-free cleaning handle, clean the lens, and then suck clean air with compressed air to blow off the attached columns and other foreign matters;
- 2、 Repeat several times until the lens is clean;
- 3、 The collimating lens is a composite double piece combination. Please pay attention to the direction;
- 4、 If the protective lens cannot be cleaned or damaged, it must be replaced with a new lens.

►Protective lens maintenance

- 1、 Loosen the two locking nuts on the protective mirror assembly by hand and pull out the protective mirror drawer;
- 2、 Note: quickly seal the opening after lens removal with non adhesive protective film!
- 3、 Put the protective lens drawer (including protective lens) in a clean environment for maintenance;
- 4、 Remove the protective film on the laser head, insert the maintained protective lens cover (including the lens) into the laser head and lock it;
- 5、 Note: the direction of the protective mirror cover. If the direction is reversed, it cannot be inserted!
- 6、 Lock the two fastening nuts on the protective lens assembly by hand with appropriate force.

►The replacement and disassembly process of protective lens is as follows:

- 1、 Screw the spring pressure ring with the special tool until the thread of the spring pressure ring is completely disengaged.
- 2、 The whole collimating spring pressing ring after loosening the spring pressing ring shall be buckled down on a clean plane (the spring pressing ring shall be kept in the collimating seat during this process), and the collimating seat 1 shall be pulled out slightly upward, taking care not to let the lens fall.
- 3、 After removing the washer placed on the lens, you can replace or maintain the lens after removing the lens.
- 4、 After maintenance or replacement of the lens, please install it in the reverse order according to the disassembly order. When locking the spring pressure ring, the force should be light to avoid damaging the lens.
- 5、 After the spring pressure ring is screwed to the end, please back 1 / 5 turn to ensure that there is a gap (0.1 ~ 0.15mm) in the spring pressure ring 3.

Note: keep the original order between the parts, and the lens should be in the same direction as the original!



Cautions:

- ★ Do not repeatedly use lint free cotton cloth or cotton swab to wipe the protective lens.
- ★ Do not touch the protective lens with your fingers.
- ★ Do not blow directly with your mouth to protect the dirt on the surface of the lens, because it may bring new dirt.
- ★ Do not touch the tip of the cleaning swab with your fingers.
- ★ Don't forget to clean when replacing the protective mirror drawer.
- ★ When using compressed air, please do not blow dirt directly from the front, but from the side to avoid dirt sneaking into the surface.
- ★ **In particular**, when cleaning the product, you must wear powder free gloves or finger covers. It is now clear that if the damage is caused by improper operation or the use of incorrect cleaning procedures or chemicals, the damage caused by this reason is not covered by the warranty.

06. Use and maintenance

6.1 Matters needing attention

1. Any parts installed in the laser head must be carefully dedusted!
2. If the lens must be replaced, the relevant work must be carried out in a clean environment!
3. Any assembly or component replacement must be carried out in a clean environment!
4. Before removing the old lens assembly, please prepare the new assembly. If there is no spare lens assembly, it is recommended to purchase from our company!
5. When the conditions are difficult to meet the requirements, the opening after lens removal shall be sealed with non adhesive protective film!
6. Minimize the exposure time of the laser head path to the air to prevent dust and dirt from entering!
7. After any safety or protection equipment is removed, it must be reinstalled before equipment operation or commissioning to check and confirm that the equipment is in good operation

6.2 Maintenance of QBH and optical fiber connector

1. The connection between QBH and optical fiber connector shall be covered with self-adhesive paper to avoid the entry of dust and increase the difficulty of maintenance;
2. The cooling water pipe of the optical fiber connector shall be well connected without water leakage. If the QBH is accidentally flooded, please stop using it immediately and return it to our company for treatment.

6.3 Precautions for regular maintenance of welded joints

1. Regularly check whether the protective lens is polluted. If there is any pollution, replace it in time (check every day);
2. Regularly check whether QBH connector is loose (every 3 days);
3. No water is allowed to enter the connecting line, and pay attention to protecting the interface part;



兴弘光电

XINGHONG OPTOELECTRONIC



武汉兴弘光电技术有限公司

WUHANXINGHONG OPTOELECTRONIC TECHNOLOGY CO.,LTD

Company address: Plant No. 1, floor 2, building B10, plot B, Phoenix Industrial Park (Wuhan, China Optical Valley Cultural and Creative Industrial Park), No. 52, Liufang Avenue, East Lake New Technology Development Zone, Wuhan

Consultation hotline: 027-81303883

Website: www.xhoptoelec.com