

HW series

HW20-B platform single oscilloscope welding head user's manual

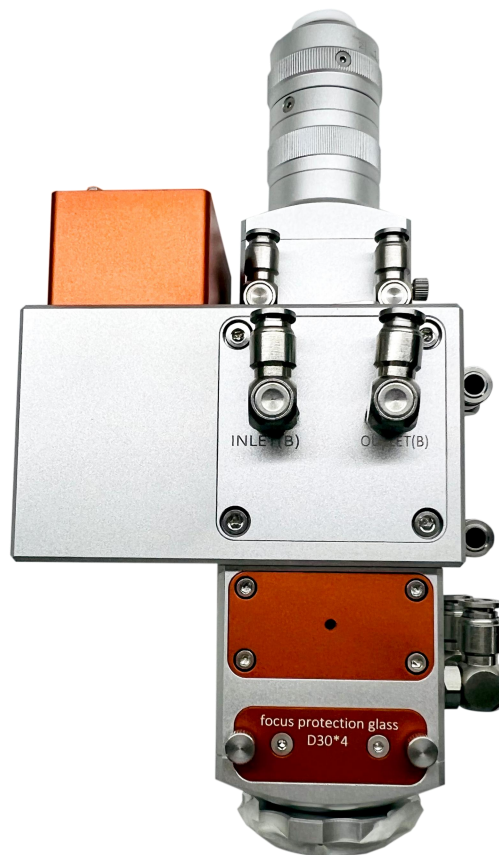

Wuhan Xinghong Photoelectric Technology Co., Ltd

2022. 08. 04

Catalogue

Chapter 1: product introduction and display

1.Product introduction	4
2. Product parameters	
3.Accessories display	5
4.Cautions: Five steps for plugging and unplugging optical fibres.....	7
5. Special note: Steps for plugging and unplugging optical fibres (new QBH connector).....	8

Chapter 2: product installation

1. Welding head installation dimension drawing	7
2. Defocus adjustment.....	7
3. Replacing the cleaning protection sheet	7-8

Chapter 3: Control system instructions

1. Reference dimensions for control panels and control boxes
2. Control box wiring diagram
3. Description of control card terminal definitions

Chapter 4: Description of the main operating parameters interface of the touch screen

1. Main operating interface
2. Advanced parameters screen
3. Mode selection screen

4. Password change screen

Revision History



**Please read this product manual carefully after
Then carry out the installation, debugging and use of the product**

You must wear safety goggles when operating laser equipment. Safety glasses should be reasonably selected according to the wavelength of the laser emitted by the laser equipment. If the device is a laser tunable or Raman product, it will emit laser light beyond the normal output wavelength range of the device's laser, and corresponding safety protection should be taken against this phenomenon during protection. Laser safety goggles should be selected based on the ability to shield the entire wavelength range of laser light emitted by laser equipment.

Chapter I product introduction and display

1.Product introduction

The "HWX30P Platform Monoscope Welding Head" is a single-axis oscillating (with integrated screen) welding head developed in-house, consisting of a "Platform Monoscope Welding Head" and an "X-Z Laser Welding Control System". The welding head consists of a QBH collimation module, a single-axis oscillator assembly, a focusing module and a CCD monitoring module.

5、QBH Joint



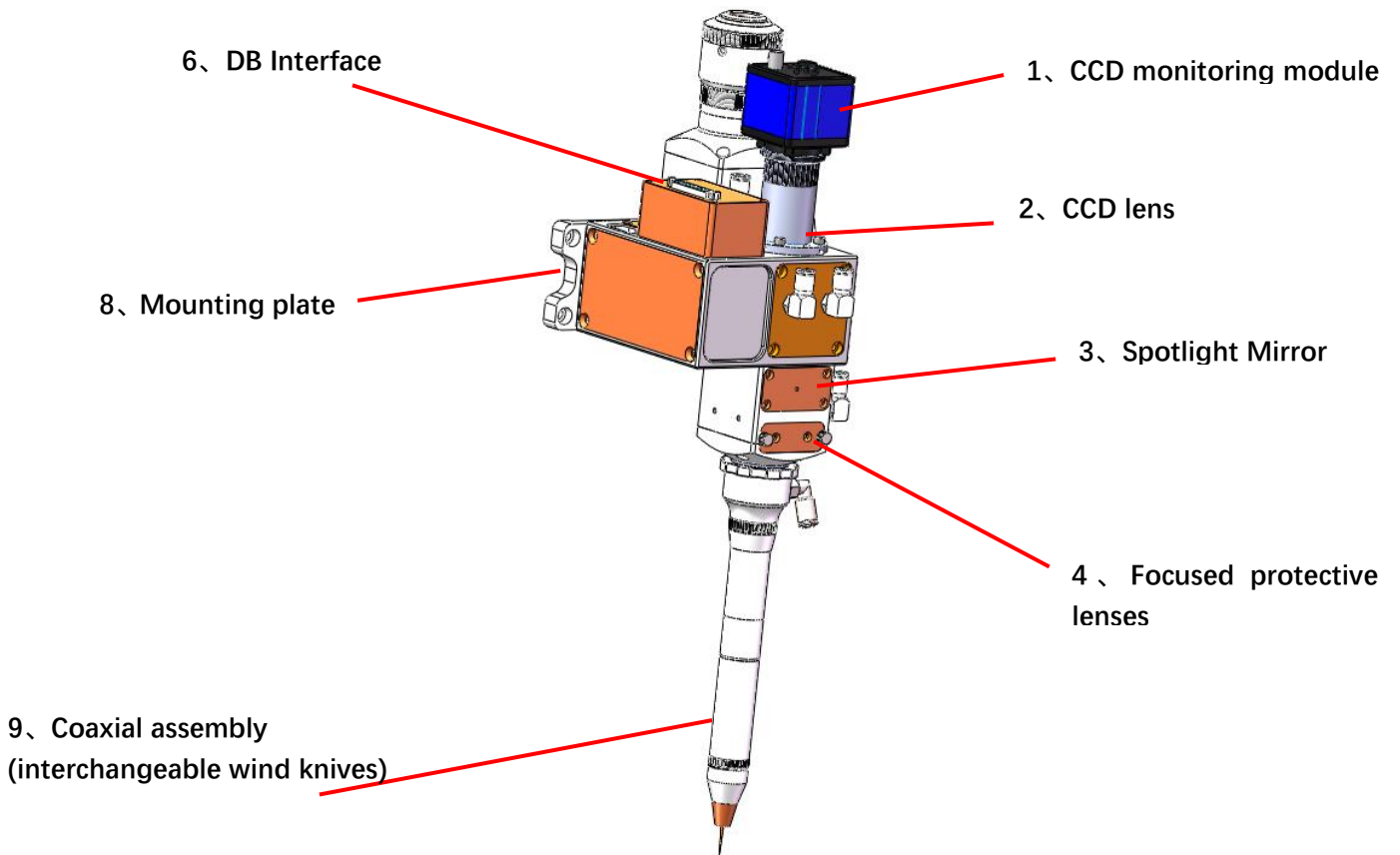

**HWX20 platform single oscilloscope welding head
(sample)**

2. Product parameters

Maximum power	2000W
Fiber interface	RD/QBH
Collimation	F75
Focus	F200/F250/F300

Clear aperture	D20mm
Collimation protection mirror	D28X4mm
Focus protector	D30X4mm
Protective gas pressure	10、15、20、25par
Weight	3.2kg

3. Accessories display

	光纤单轴振镜焊接头
	±15V power supply
	Serial signal cable

	Control Cards
	Connecting cable
	Control screen
	8" monitor
	BNC line

	Side-shaft blowing
	Side-shaft blowing
	Side-shaft blowing
	wind knife assembly
	Coaxial blowing
	Blue Light
	Protective sheets
	Accessories

4. Special attention: 5 steps for inserting and unplugging optical fiber

Note: when inserting optical fiber, the laser head shall be placed horizontally; Ensure that the optical fiber is inserted horizontally

- 3. 1** Check whether QBH connector and optical fiber plug are dirty, and wipe them with alcohol and cotton swab (cotton paper) in time



3.2 QBH homing "two points and one line" 3.3 alignment insertion of optical fiber plug



3.4 secondary locking clockwise 3.5 optical fiber protective jacket for complete protection



Note: when inserting optical fiber, the laser head shall be placed horizontally; Ensure that the optical fiber is inserted horizontally

5、 Special note: Steps for plugging and unplugging optical fibres (new QBH connectors)

5.1 Inspect QBH connectors and fibre plugs for dirt and wipe them clean promptly with alcohol and cotton swabs (cotton paper).



5.2 The QBH is in the unlocked position (arrow pointing to the unlocked logo) and the red dot of the fibre optic plug is inserted into place against the red dot on the end of the QBH.

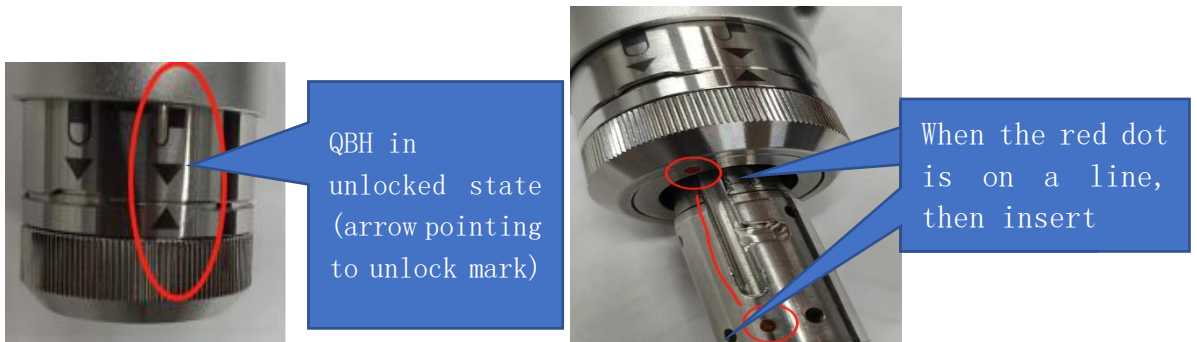

5.3 Turn the ring with the lock mark on the QBH connector clockwise until the QBH is in the off-lock position (arrow pointing to the off-lock mark) and finally twist the locking ring to tighten it.

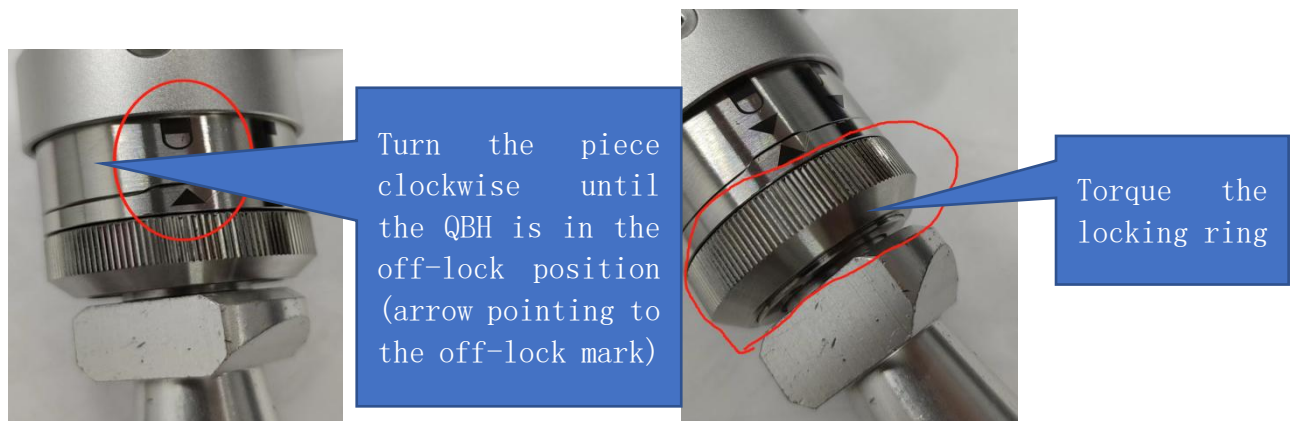

Chapter 1 Introduction to Product Functions and General Operations

1. Welding head installation dimension drawing

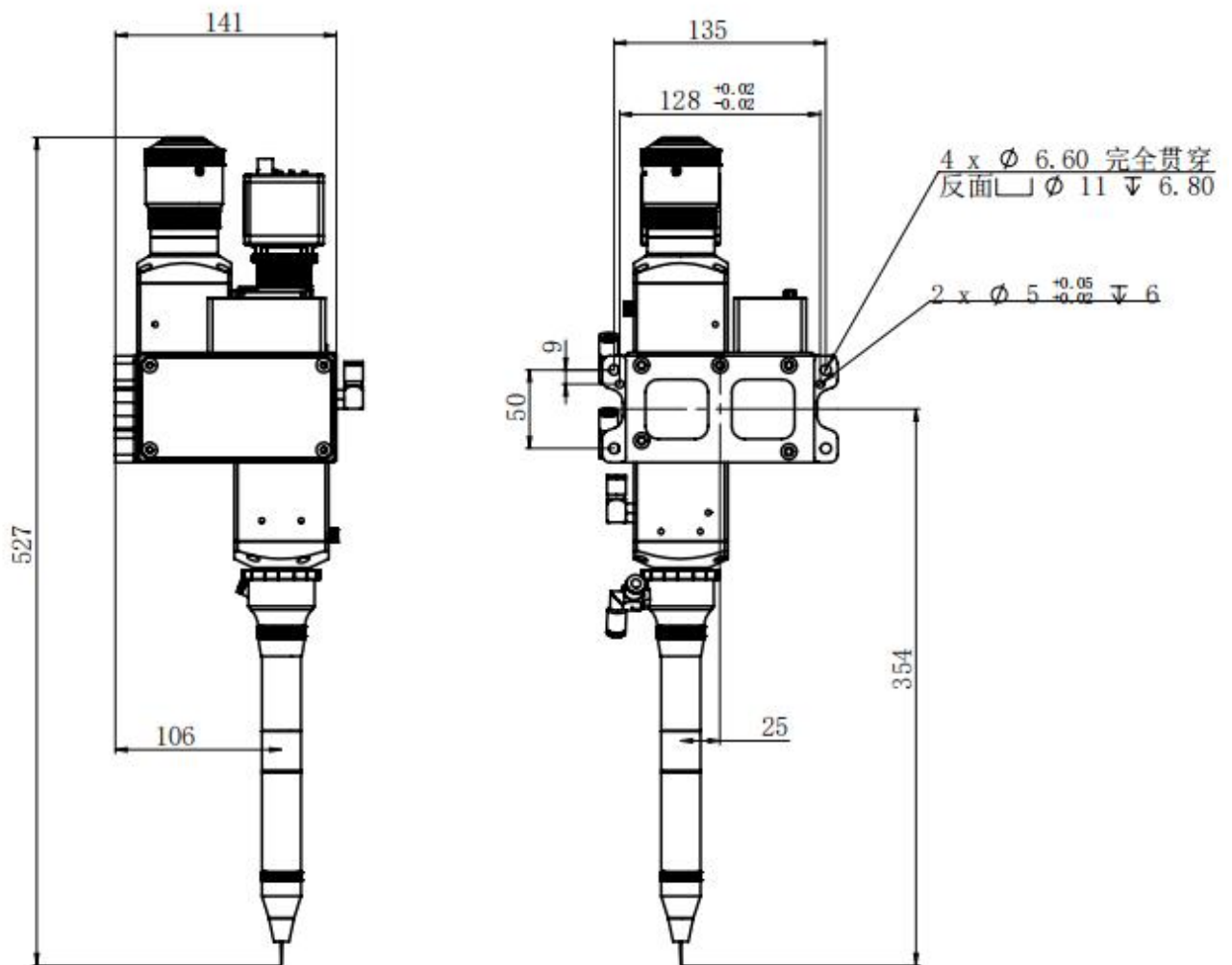

2. Defocus adjustment

Adjust the laser power to about 150W, the laser beam brightness is the strongest, "snort" sound maximum, hear the snap only when the focal point is located exactly on the surface of the workpiece, which is zero defocusing.

Negative defocusing, you can get a greater depth of melting, the internal power density of the material is higher than the surface, easy to form a stronger melting, vaporization, so that the light energy to the material deeper transfer. Therefore, in practice, when a greater depth of fusion is required, negative defocusing is used; when welding thin materials, positive defocusing is appropriate.

3、 Replacing the cleaning protection sheet

Importance: When cleaning and replacing the protective sheet, you will need the following:

1. Powder-free rubber gloves or finger gloves, lint-free cleaning wipes and cotton swabs
2. Isopropyl alcohol (optical grade, anhydrous), acetone (optical grade, anhydrous), ethanol
3. Compressed air (oil-free, water-free)
4. Light source

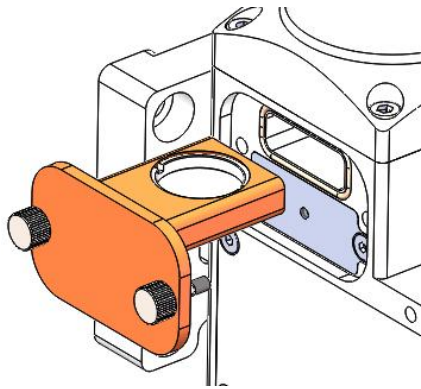

Collimation Mirror Drawer (Threaded Press Ring)

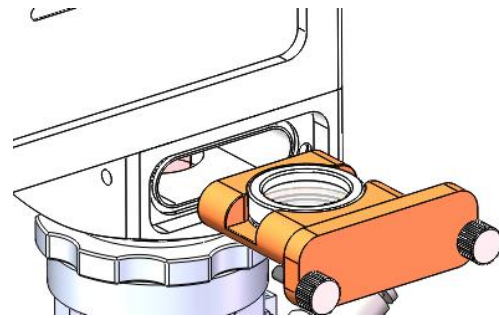

Focus protection mirror drawer (pan plug seal)

★Notice:

★ Do not go back and forth, use a lint-free cotton cloth or cotton swab to wipe the protective lens.

★ Do not touch the translucent surface of the protective lens with your fingers.

★ Do not blow directly with your mouth to protect the dirt on the surface of the lens, because it may bring new dirt.

★ Do not touch the tip of the cleaning swab with your fingers.

- ★ Don't forget to clean when replacing the mirror drawer.
- ★ When using compressed air, please do not blow the dirt directly from the front, and use the method of blowing from the side to prevent the dirt from sneaking into the surface.
- ★ Special instructions, powder-free gloves or finger cots must be worn when cleaning the product. It is now clear that if the damage is caused by, improper handling or the use of incorrect cleaning procedures or chemical use, damage due to such causes is not covered by the warranty.

Chapter 3: Control system instructions

1. Reference dimensions for control panels and control boxes



屏幕安装开孔尺寸
197.4mm*137.1mm

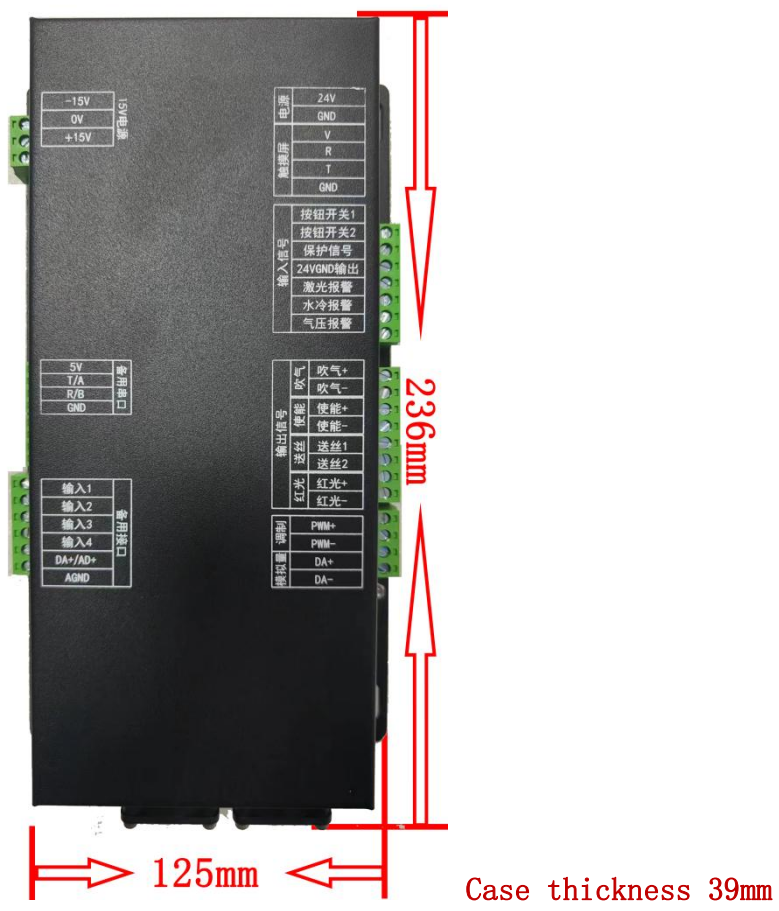

2 . Wiring diagram for control box (below)

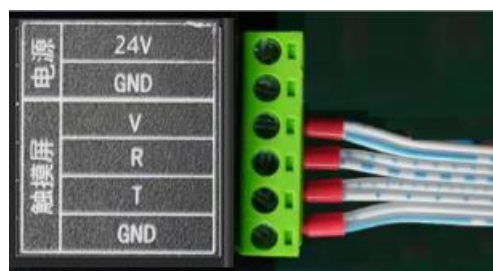
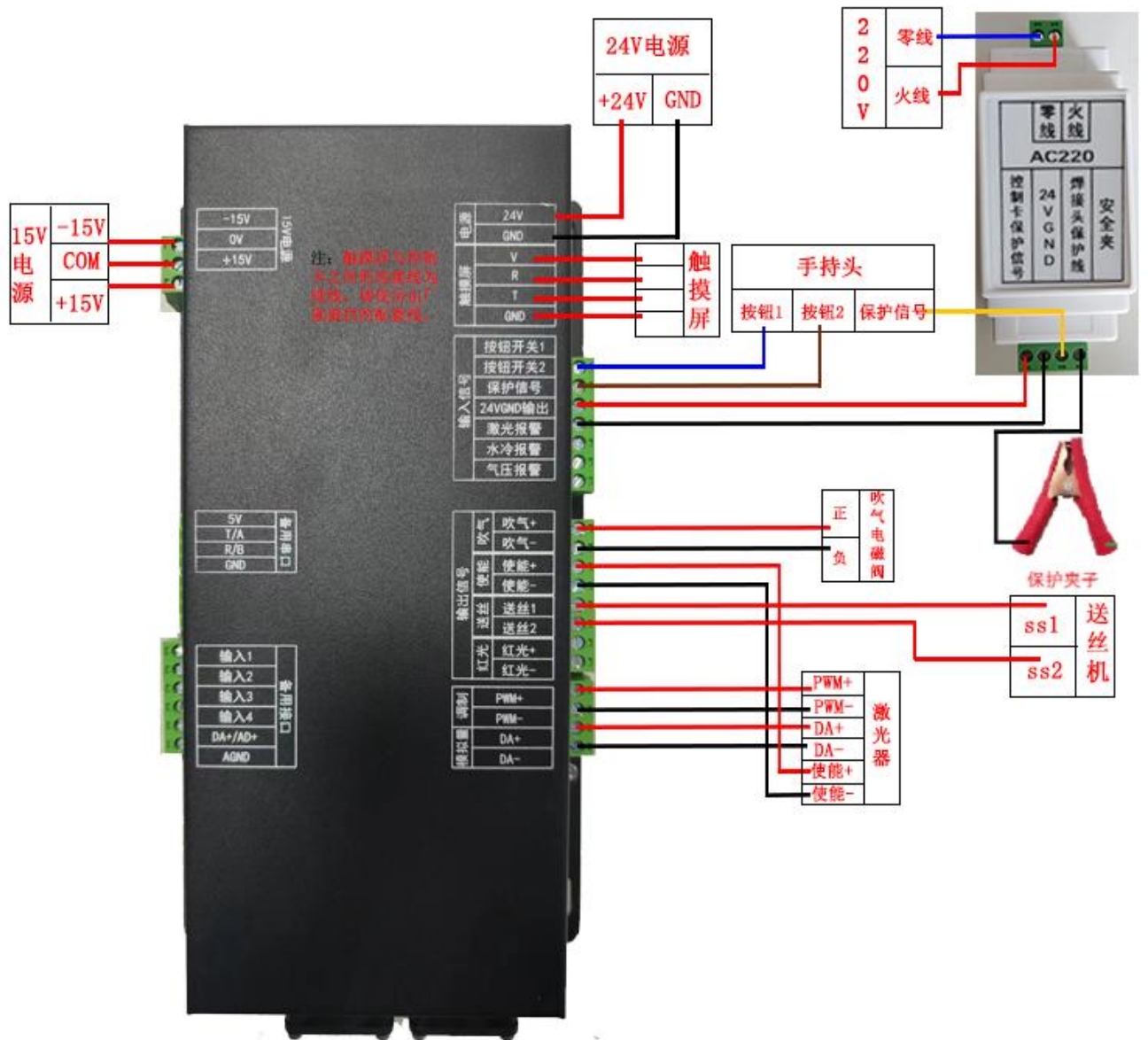

The correct way to connect the touchscreen matching cable

3. Description of the control card terminal definitions (below)

Left

Name	Definition	Explanation
15V power supply	-15V	-15V
	COM	COM
	15V	+15V
Alternative serial port	5V	Alternative serial port
	T	
	R	
	GND	
Alternative interfaces	input1	standby
	input2	standby
	input3	standby
	input4	standby
	DA+/AD+	standby
	AGND	standby

Right

Chapter 4: Description of the main operating

Name	Definition	Explanation
power	+24V	+24V
	GND	24VGND
Touch screen	V	For cable connections, please use the matching cable provided by the manufacturer
	R	
	T	
	GND	
Input signal	Push button switch 1	Hand-held switch button 1
	Push button switch 2	Hand-held switch button 2
	Protect Signal	Connection to isolation module control card protection signal
	24VGND Output	Connected to isolation module 24VGND
	Laser ERR	Laser alarm signal connected, 24v ground active
	Cool ERR	Water-cooled alarm signal connected, active 24v ground conduction
	Stop	Air pressure alarm signal connected, 24v ground active
Blow	Blow+	Positive air connection valve
	Blow-	Negative air connection valve
Laser-EN	Laser-EN+	Connect laser enable positive
	Laser-EN-	Connect laser enable negative
Wire Feeding Switch	Wire Feeding 1	Wire feeding ss1
	Wire Feeding 2	Wire feeding ss2
Red Light	Red Light+	Connected to red light positive
	Red Light-	Connected to red light negative
Modulated Analogue	PWM+	Connected to laser modulation +
	PWM-	Connected laser modulation-
	DA+	0-10V signal 0-10V analogue signal to laser positive
	DA-	0-10V signal ground 0-10V analogue signal to laser negative

parameters interface on the touch screen

1. Main operating interface

Once powered up the touch screen enters the main operating interface (Figure A below).



● The interface status bar shows: communication indication, air pressure alarm, laser alarm and water cooling alarm in order.

1. Communication indication: if the light is green and flashing, it indicates that the touch screen and the main control card are connected normally; if it is not flashing, it indicates that the control card and the touch screen are communicating abnormally.

2. Air pressure alarm: red light shows that there is a problem with the laser, dark green is disconnected or this function is not connected to the signal.

3. Laser alarm: red light shows a problem with the laser, dark green is disconnected or this function is not connected to the signal.

4. Water cooling alarm: red light shows that there is a problem with the water cooler, dark green for disconnection or this function is not connected to the signal.

5. Run/Stop: Click on the button to start/stop the welding process, when the button is green to run the process is running, when the button is red to stop the process is stopped.

6. Advanced parameters: Click to enter the advanced parameter setting interface as shown in Figure B.

7. Language: Click to switch the language.

●Parameter field

1. Laser power: set the current light power, must not be greater than the laser

power

2. PWM frequency: set the frequency of PWM modulation signal, 0-200000HZ adjustable
3. PWM duty cycle: set the duty cycle of the PWM modulation signal, 0-100% adjustable
4. Oscillator width: set 0-5 (0-5 for welding mode, 0-120 for cleaning mode)
5. Vibrating mirror frequency: frequency can be set from 0-200
6. Oscillator switch: control the oscillation of the oscillator on and off

● Input status bar

1. Push button switch: Shows the on/off status of the handheld head switch signal, dark green is off, green is on, default is off
2. Protection signal: shows the on/off status of the protection signal, dark green is off, green is on, default is off

● Output status bar (can be clicked to output the corresponding signal when the weld program is stopped. For testing)

1. Blow: activates/deactivates the blow signal function to test the blow electronic valve on/off
2. Laser enable: activates/deactivates the laser enable signal to test the laser's laser enable
3. Wire feed: the wire feed signal function tests the feed of the laser wire feeder
4. Red light: activates/deactivates the red light signal to test the on/off of the red light function

● Light output mode

1. Output time: This parameter is only valid for single and continuous spot welding.
2. Interval time: This parameter is only valid for continuous spot welding.
3. Continuous: the laser will emit light continuously after the trigger.
4. Single spot welding: after triggering, the laser emits light according to the set emitting time.
5. Continuous spot welding: After triggering, the laser continuously spot welds according to the set output time and interval.

● 1. Software version number: Displays the current board software version number.

2. Firmware Version Number: Displays the current board firmware version number.

3. Click the "Language" button at the bottom right of the main interface to enter the English interface.

4. Click the "Advanced Parameters" button at the bottom right corner of the main interface to enter the advanced parameters interface.

2. Advanced parameters screen

After clicking on Advanced Parameters in the main interface, you will enter the Advanced Parameters interface (Chinese interface as shown in Figure B below)



Figure B

●Parameter field

1. Laser power: Set the maximum power of the laser, unit W.
2. On delay time: Set the time to blow air before welding starts, in ms.
3. Off gas delay time: Set the time to keep blowing gas after welding is finished, unit ms.
4. Power on: Set the initial power of the laser when it is out, unit W.
5. Slow rise time: Set the slow rise time for the start of the light output phase, unit ms.
6. Off power: set the end power of the laser when closing the light, unit W.
7. Slow down time: Set the slow down time at the end of the welding closing stage, unit ms.
8. Advance wire feed time: If you need to advance the wire feed before starting laser welding, set the corresponding advance wire feed time, if not, change to 0, unit ms.
9. Light off delay time: set the time for the laser to continue to keep the light out during the process of drawing the wire back from the gun head at the end of the wire feed welding, unit ms.
10. Protection signal disconnection time: The maximum time allowed for the protection signal to be disconnected during program operation to prevent the

light from being broken by hand shake.



1. Protection signal: start/close protection signal, red is off, green is start, default start
2. Wire feed switch: start/close wire feed switch signal, red is off, green is on, default start.

●Process library

Different process libraries can be selected to set up separate calls for different parameters



1. Click the "Vibrator Settings" button at the bottom right of the Advanced Parameters screen to enter the Vibrator Settings screen.
2. Click on the "Exit" button at the bottom right of the Advanced Parameters screen to return to the main screen.

Click on the "Vibrator Settings" button at the bottom left of the Advanced Parameters screen to enter the Vibrator Settings screen as shown in Figure C below.

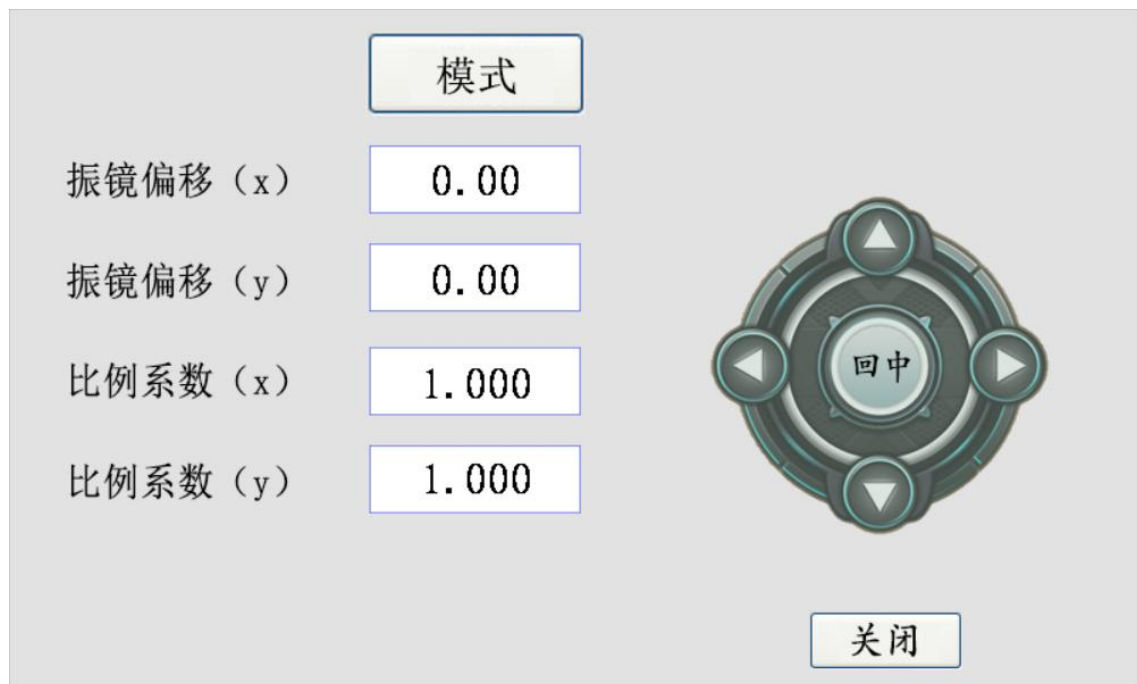

Figure C

●Vibrator settings

1. Oscillator offset: The oscillator offset button controls the offset of the origin of the oscillator, the oscillator offset (x/y) controls the offset of the origin in the horizontal and vertical directions respectively, in the range of -5-5 mm

2. Return to centre: the adjusted offset can be returned to zero
3. Scale factor: adjusts the magnification of the adjustment, in the range 0-5
4. Close: return to the upper screen
5. Mode: click to enter the mode selection interface, as shown in Figure C

3. Mode selection screen

Click on the mode button at the top left of the oscilloscope settings to enter the mode selection interface, as shown in Figure D



Figure D

● Mode selection

The current mode is welding mode, click on it to enter the main welding interface as shown in Figure A.

Click on the cleaning button to jump to the main screen as shown in figure E



Figure E

4. Password change screen

Click on the hidden button in the red box at the top left of the Advanced Parameters screen as shown in Figure F to access the password change screen as shown in Figure G.



请输入六位新密码:

新密码:

确认新密码:

●Password Change

To change your password, first enter your new password, then enter to confirm the new password, click OK to change your password, click Cancel to return to the upper screen.

Revision History

Date	Revised content	Software Versions
20220804	First Edition (First Release)	V1.0
Wuhan Xinghong Photoelectric Technology Co., Ltd. TEL: 18971055224(After Sales Manager of South China Office) 15888537533(After Sales Manager of East China Office) 18086021608(After Sales Manager of North China Office)		